

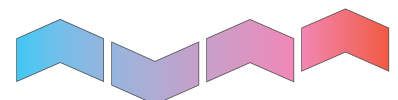

PRECISION AIR CONTROL FOR SCHOOLS



ENVIRONMENTAL
COST-EFFECTIVE SOLUTION



PRECISION AIR CONTROL FOR SCHOOLS

Control System Benefits:

- CM Integral control system that can be monitored and adjusted by central BMS.
- CO₂ sensor constantly monitors and maintains CO₂ levels by controlling the fresh air ventilation rate.
- Air volumes and differential control valves are factory commissioned and monitored by onboard controls, saving site commissioning.
- Teacher hand controller for remote monitoring and fine adjustment.
- Dirty filter monitoring – Fan speed is automatically controlled to maintain design airflow as filter pressure increases.
- Energy efficient EC fans.

Moducel is a division of the Eaton-Williams Group with over 60 years' experience in the design and manufacture of air conditioning, air handling and humidification equipment. They supply hotels, banks, sports and leisure centres, hospitals, supermarket chains, stadiums, pharmaceutical buildings and office complexes with uniquely designed solutions to suit each individual project.

Designed for schools

Moducel have designed an energy-efficient, cost-effective, fresh air unit with sophisticated refinements to deliver a constant, comfortable, healthy environment.

Classroom air quality is maintained by a ceiling mounted fresh air unit which controls air volume and maintains CO₂ levels below 1,000 ppm or any other set-point condition. The unique Moducel system controls the classroom environment and automatically

controls airflow and temperature to compensate for varying levels of classroom occupation, resulting in considerable energy savings.

CO₂ sensor

A sensor monitors CO₂ levels and communicates with the main control panel which can be linked to the central BMS.

All air filters become blocked over a period of time resulting in a reduction of air flow. Moducel fresh air units have the unique facility to automatically increase the fan speed to compensate for air flow reduction which is monitored and relayed to the main control panel.

Factory built, no commissioning

Air volumes and differential control valves are factory commissioned and monitored by onboard controls, saving site commissioning. There is a facility for remote monitoring and fine adjustment via a hand controller.



Ceiling mounted fresh air unit

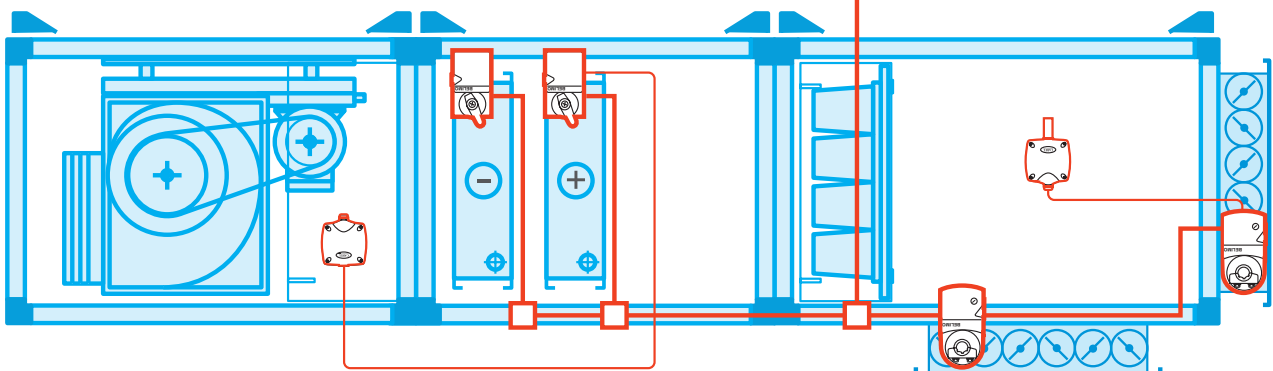

CONTROL PANEL SENSOR CONFIGURATION



Hand Controller.

Moducel a market leader in the design and manufacture of Air Handling Equipment now offer a microprocessor control system for their range of fresh air units.

The unit range has been extended to 15 models with air volumes up to 800 litres/sec and fan pressures up to 150 Pa.

Control System

The new control system has been designed to simply and flexibly satisfy the highest number of functions. A total of 24 different pre-configured functions are

available and can be selected by setting just one parameter.

The controller is positioned to one side of the unit and internally wired to the sensor, valves, actuators and fans. Site wiring is reduced to a minimum.

The controller is able to communicate with all the supervisory systems present on the market, making it an ideal choice for running with an existing building management system.

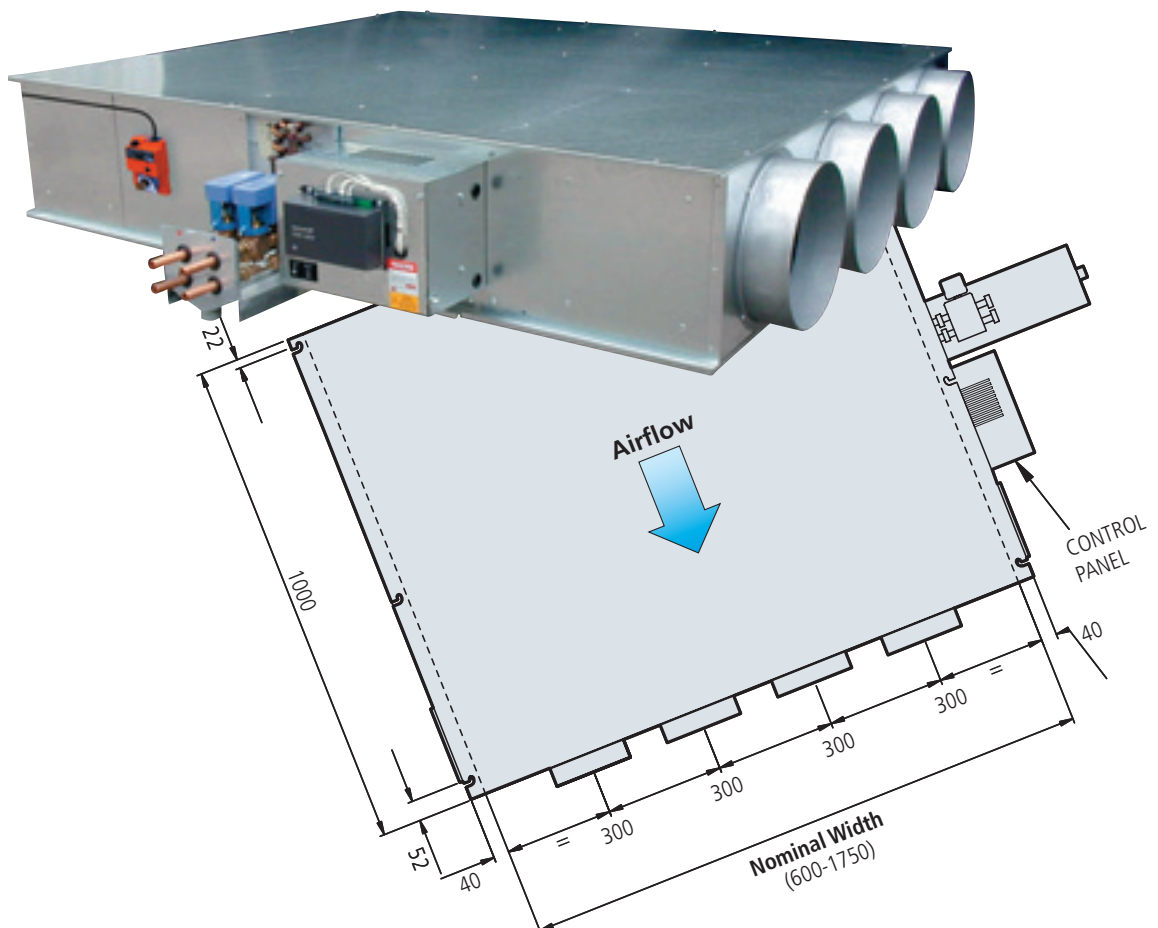
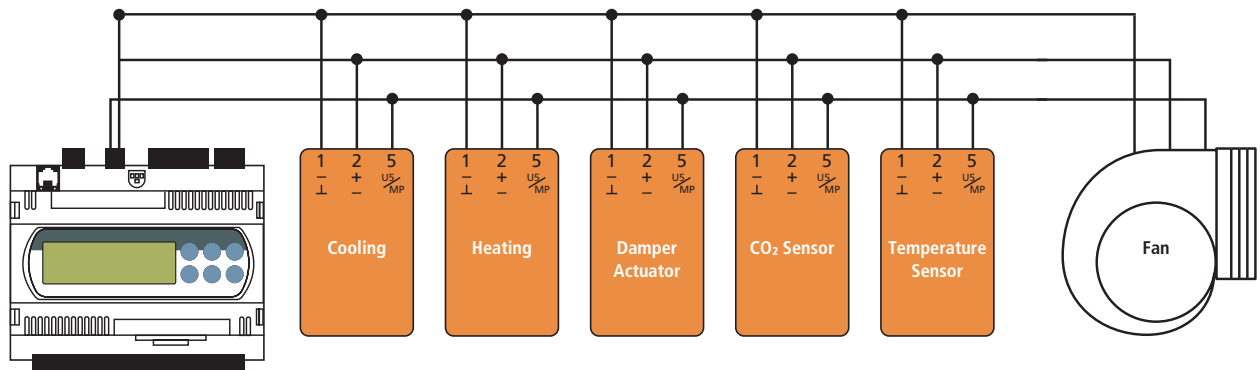

TECHNICAL SPECIFICATION

Based on LTHW 80/60, CW 6/12, Noise Level NR35, Ext Resist 50 Pa.

Model	Heating (kW)				
	5	10	15	20	25
WEC 235105dip	5.5	10.5	15.5	20.5	25.5
WEC 235208dip	5.5	10.5	15.5	20.5	25.5
WEC 235312dip	5.5	10.5	15.5	20.5	25.5
WEC 235414dip	5.5	10.5	15.5	20.5	25.5
WEC 285A105dip	5.5	10.5	15.5	20.5	25.5
WEC 285A208dip	5.5	10.5	15.5	20.5	25.5
WEC 285A312dip	5.5	10.5	15.5	20.5	25.5
WEC 285A414dip	5.5	10.5	15.5	20.5	25.5
WEC 285A517dip	5.5	10.5	15.5	20.5	25.5
WEC 335312dip	5.5	10.5	15.5	20.5	25.5
WEC 335414dip	5.5	10.5	15.5	20.5	25.5
WEC 335517dip	5.5	10.5	15.5	20.5	25.5

Model	Cooling (kW)			
	5	10	15	20
WEC 235105dip	5.5	10.5	15.5	20.5
WEC 235208dip	5.5	10.5	15.5	20.5
WEC 235312dip	5.5	10.5	15.5	20.5
WEC 235414dip	5.5	10.5	15.5	20.5
WEC 285A105dip	5.5	10.5	15.5	20.5
WEC 285A208dip	5.5	10.5	15.5	20.5
WEC 285A312dip	5.5	10.5	15.5	20.5
WEC 285A414dip	5.5	10.5	15.5	20.5
WEC 285A517dip	5.5	10.5	15.5	20.5
WEC 335312dip	5.5	10.5	15.5	20.5
WEC 335414dip	5.5	10.5	15.5	20.5
WEC 335517dip	5.5	10.5	15.5	20.5

Model	Airflow Rate (litres/sec)					
	100	200	300	400	500	600
WEC 235105dip	100	200	300	400	500	600
WEC 235208dip	100	200	300	400	500	600
WEC 235312dip	100	200	300	400	500	600
WEC 235414dip	100	200	300	400	500	600
WEC 285A105dip	100	200	300	400	500	600
WEC 285A208dip	100	200	300	400	500	600
WEC 285A312dip	100	200	300	400	500	600
WEC 285A414dip	100	200	300	400	500	600
WEC 285A517dip	100	200	300	400	500	600
WEC 335312dip	100	200	300	400	500	600
WEC 335414dip	100	200	300	400	500	600
WEC 335517dip	100	200	300	400	500	600

Model	Student Levels						
	10	20	30	40	50	60	70
WEC 235105dip	10	20	30	40	50	60	70
WEC 235208dip	10	20	30	40	50	60	70
WEC 235312dip	10	20	30	40	50	60	70
WEC 235414dip	10	20	30	40	50	60	70
WEC 285A105dip	10	20	30	40	50	60	70
WEC 285A208dip	10	20	30	40	50	60	70
WEC 285A312dip	10	20	30	40	50	60	70
WEC 285A414dip	10	20	30	40	50	60	70
WEC 285A517dip	10	20	30	40	50	60	70
WEC 335312dip	10	20	30	40	50	60	70
WEC 335414dip	10	20	30	40	50	60	70
WEC 335517dip	10	20	30	40	50	60	70

Typical Example

WEC 285A312dip unit is rated @ 15.3 kW Heating, 8.9 kW Cooling, 333 litres/sec Fresh Air, 41 Students.



Eaton-Williams Air Conditioning

Oldfields Business Park
 Birrell Street, Fenton
 Stoke-on-Trent ST4 3ES
 Telephone: +44 (0)1782 599995
 Facsimile: +44 (0)1782 599220
www.eaton-williams.com



We reserve the right to alter specifications without notice and products will sometimes be supplied with modifications which do not strictly comply with the descriptions and illustrations in this publication.